

mei® 7312 MDB Installation Guide

GENERAL INFORMATION

This document contains information for installing the MEI CASHFLOW™ 7312 coin changer.

- 7312 Multi-Drop Bus (MDB)

This product fits into the standard coin changer channel provided by vending machine manufacturers. It mounts on the existing three mounting studs/screws located in the vending machine.

The features of the coin changer include:

- Changeable/configurable coin cassette
- Five auto-replenishing coin tubes (flexibility)
- \$1 coin payout
- Patented coin inventory recognition
- MDB interface
- Ability to manage coin inventory to minimum levels

Interface

MEI CASHFLOW™ 7312 operates in machines that support the MDB interface*. MDB is a serial communication interface standard that has migrated into vending equipment since 1996. It allows for multiple devices to be added to a single connection on the vending machine control board, by linking one device to another in series to the main MDB harness.

Rated Operating Voltage

Voltage: 34v d.c. 12W

The operating voltage of a MEI CASHFLOW™ 7312 coin changer is stated on the label of each product. The label is located on the left side of the coin changer.

**Note: MDB (Multi drop bus) interface information can be found on NAMA's website located at www.vending.org*

MEI

Technical Support 1(800)345-8172
Customer Support 1(800)345-8215
<http://www.meigroup.com>



INSTALLATION INSTRUCTIONS

Before you begin...

- Remove the coin changer from the packaging material. Inspect unit for physical damage that may have occurred during shipping.

- Turn OFF the power supply to the vending machine.

- Push and hold the yellow acceptor release button on the top right (below reject lever) of the coin changer and tilt the acceptor assembly forward. You do not have to remove the cassette (See Fig 1).

- Once open, the mounting holes are accessible. Hang the coin changer on the mounting studs/screws, ensuring that the changer is mounted on all three studs/screws (See Fig 2).

- Tighten screws (if required) and close the acceptor assembly.

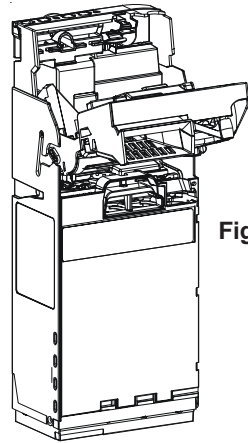

Fig. 1

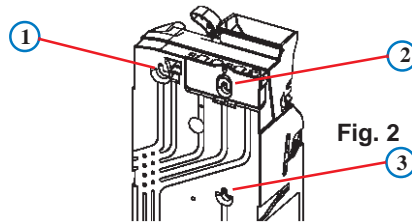

Fig. 2

- Remove cassette by sliding two fingers in the yellow latch and lift the cassette outwards and upwards as shown in Fig. 3.

- Manually fill cassette with coins. Insure that coins are inserted into the proper tubes.

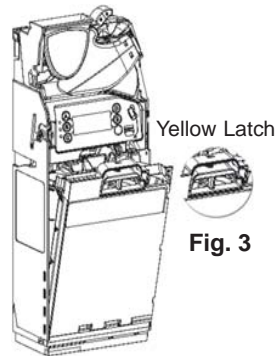
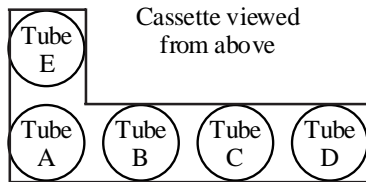

Fig. 3

Notes

Notes

Alignment

- Once the coin changer is installed, check that there is a small gap (2-4 mm) between the lever on the vending machine and the return lever on the coin changer (See Fig 4). Check that when you press the coin return lever on the machine door, it fully opens the acceptor lid on the coin changer, then returns smoothly without holding the lid open.

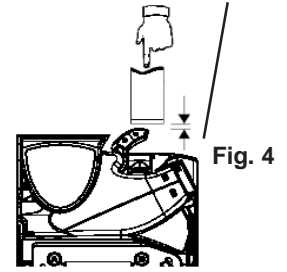

- Check the alignment of the coin input chute and cashbox chute. Insert some coins to check that they enter the coin changer properly and exit into the return cup (See Fig 5). Ensure that the coin chute does not rest on or open the flight deck lid.

Most machines allow you to adjust the return lever, coin chute, and the return cup to align with the coin changer. Align, adjust, and test as necessary to ensure coins are properly routed before continuing with these instructions.

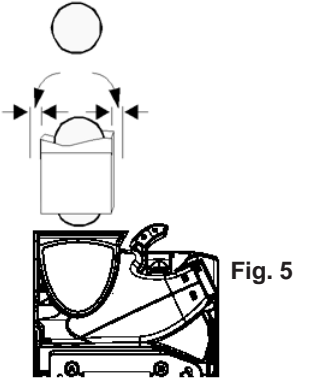

Connection

An MDB (Multi-Drop Bus) coin changer will transmit both power and communication from the vending machine to the coin changer through the six pin connector.

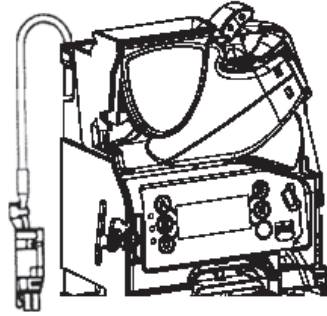

- If you have a bill acceptor, connect the MDB harness coming from the coin changer to the bill acceptor's "Y" connector.

If there is no bill acceptor, connect the coin changer harness to the harness coming from the machine's control board.

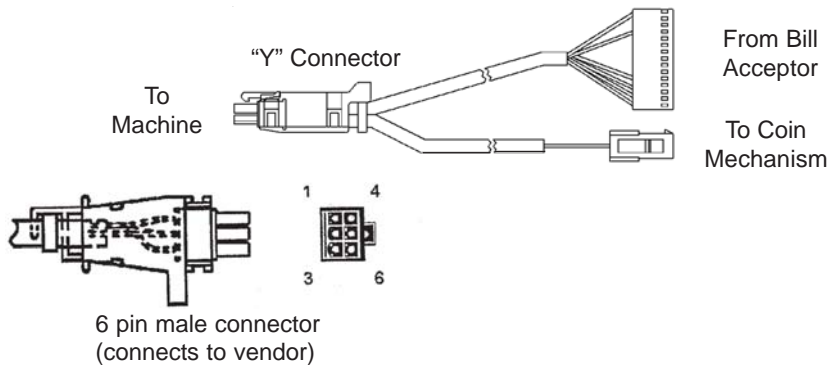

- Tuck any excess length of harnessing inside the machine. Make sure all harnesses are not trapped when the coin return lever is pressed or when the vending machine door is closed.

- Now you may switch "ON" the power to the vending machine.

Notes

Service Mode Features

CASSETTE

Check with our customer service representative on availability of several of these cassette configurations:

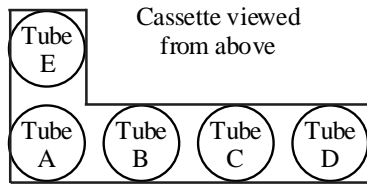

USA Cassettes

Key Code	Tube A	Tube B	Tube C	Tube D	Tube E
AA	10c	5c	25c	25c	5c
AB	10c	5c	25c	\$1	5c
BA	25c	5c	25c	25c	25c
BB	10c	5c	10c	25c	5c
DAC	25c	5c	\$1	\$1	25c
DCA	25c	10c	25c	\$1	5c
DCB	25c	10c	\$1	\$1	5c
DCC	25c	10c	25c	25c	5c
DCD	5c	10c	10c	10c	5c
DCE	10c	10c	10c	10c	5c

Follow instruction on the front of the cassette

The coin changer can also be custom configured by a MEI authorized service center downloading software. But there are restrictions on tube placement.

Always include at least one 5c tube in all custom configured cassettes.

Do not place the \$1 tube in tube A or B position.

Do not place the 25 cent tube in tube B position.

Do not place the 10 cent tube in tube E position.

Coin	Tube # & Base Color	Max Fill (\$) (by coin manager)	Manual Fill(\$) (do not fill more than)	Position In cassette
5c	22 Red	77 (\$3.85)	87 (\$4.35)	A,B,C,D,E
10c	19 White	115 (\$11.50)	127 (\$12.70)	A,B,C,D
25c	25 Black	84 (\$21.00)	96 (\$24.00)	A,C,D,E
\$1	27 Blue	69 (\$69.00)	81 (\$81.00)	C,D,E

For additional instructions on tube positioning, you may contact our help desk at 1-800-345-8172.

Initial Power Up (First Time Out of Box)

The coin changer will power up and check to see how many coins are in each tube. If the tubes are empty or low on coins the coin changer will alert you with 5 amber flashes. The coin changer will remain disabled until you fill the three lowest coin value tubes with a minimum of five coins per tube (i.e. On a 5,5,25,10,25 configuration, you would have to fill tubes ACD).



Fig. 6

Once you've filled the cassette with coins, the coin changer will measure the tubes for 5 seconds and display a solid Green light. Dispense some coins from each tube to check that all coins drop into the coin return cup properly.





Fig. 7

LED Light Codes

- The 3 LEDs fitted on the coin changer provide up to the minute status information. Please refer to the following tables for more details.

●	On	=Coin changer OK
●●●	Cycles x 5	=Normal power up/Reset (prior to going solid green)
●	blinks off	= Coin accepted/ Rejected (Refer to green LED Codes on the next page)
●	Flashing	= In Menu Mode (Refer to green LED Codes)
●	On	=Coin changer Inhibited by VMC
●	Flashing	= Requires Attention (Refer to amber LED Codes)
○	Off	=No power to the coin changer
●●	On	=Coin changer Faulty (Send unit in for repair)

Green LED Codes

Coin Accepted / Rejected	Coin discrimination LED codes
 1 x Blink	= Inserted coin was accepted
 2 x Blink	= Inserted coin was rejected - unknown (not recognized by discriminator)
 3 x Blink	= Coin rejected (Inhibited by machine or coin changer program settings)

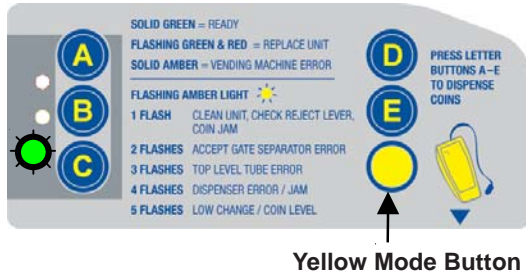
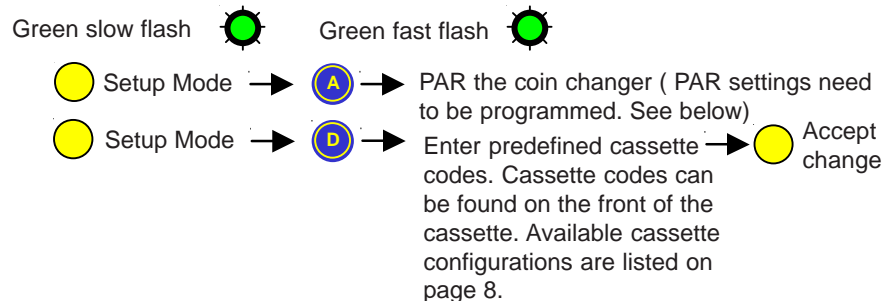

Fig. 8

Yellow Mode Button

If you press the yellow mode button, the coin changer will go into setup Mode. The green LED will continuously flash slowly while in setup mode for approximately 1 minute or until you make a selection.

Once in setup mode you may press **A** to PAR the coin changer or **D** to enter a cassette code. Once you make a selection either to PAR or to change the cassette code, the green light will start to flash fast. You must begin to PAR the coin changer or enter the cassette code while it is fast flashing. If you do not make a selection or insert a coin for approximately 1 minute, the coin changer will exit out of setup mode and the light will return to a solid green.







PAR (Continued)

sending the coins to the cashbox. To set or change PAR settings on a CF7312 you will need to use a Cashflow Programming Module (CPM) or have a service center reprogram the coin changer using STS software. An authorized service center can program your coin changer to par at a certain dollar amount. Once programmed, when you enter par mode, the green light will start to flash fast. If you have less coins in the tubes that the set dollar amount, you will need to insert coins until the coins start to be dispensed. If you have more than the set dollar amount, the coin changer will automatically dispense the excess coins.

Please contact our MEI technical support department for any additional information regarding PAR options.

Amber LED Codes

The amber LED allow you to pinpoint a fault that may have occurred on one of the modules of the coin changer. These types of faults can be rectified at the machine.

 1 x Flash	= Discriminator error
 2 x Flash	= Accept gate error
 3 x Flash	= Separator module top level sensor Tube cassette error or missing cassette
 4 x Flash	= Dispenser module error
 5 x Flash	= Low on change

PAR

The PAR default setting (setting from the factory) is Par to Level "full". Which means the PAR Level is set to fill the tubes to the maximum level prior to